



# Evaporadores Perfil Alto

Modelos FBHA | FBHE/FBHL | FBHG/FBHF

# FBH

Evaporadores FB  
Alto perfil

A=6 APP Deshielo por Aire  
E=6 APP Deshielo Eléctrico  
L=4 APP Deshielo Eléctrico  
G=6 APP Deshielo por Gas Caliente  
F=4 APP Deshielo por Gas Calient

# A

# 850

Capacidad x 100  
(Motor / Aspas Ventilado Estándar)

# C

Voltaje

B=208-230/1/60

C=208-230/3/60

D=460/3/60

M=460/1/60

N=110/1/50

X=380/400/3/50

Y=200/220/1/50

Motores (opcional)  
T=Totalmente cerrado  
V=Alto volumen de aire  
P=4Motor trifásico

# P

Diseño

# A



## DESHIELO POR AIRE, ELÉCTRICO Y GAS CALIENTE

## Motores a 850 rpm silenciosos

- Motores a 850 rpm silenciosos y confiables
- Su diseño thermoflex (garantía limitada 5 años) es innovador, elimina fugas, reduce la pérdida de refrigerante.
- Cableado para la solenoide de líquido con conexión rápida para una instalación oportuna.
- Control de deshielo ajustable para calibrarse de acuerdo a la aplicación.
- Tiro de aire largo ideal para bodegas grandes y aplicaciones industriales
- Tablero terminal estandarizado para hacer más fáciles las conexiones o cableado en el campo.

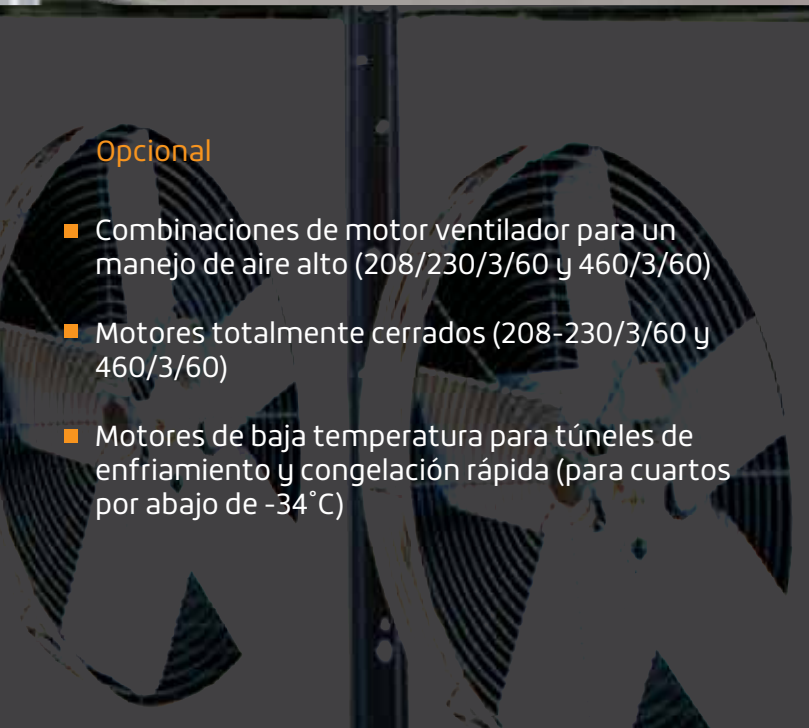

### Opcional

- Combinaciones de motor ventilador para un manejo de aire alto (208/230/3/60 y 460/3/60)
- Motores totalmente cerrados (208-230/3/60 y 460/3/60)
- Motores de baja temperatura para túneles de enfriamiento y congelación rápida (para cuartos por abajo de  $-34^{\circ}\text{C}$ )

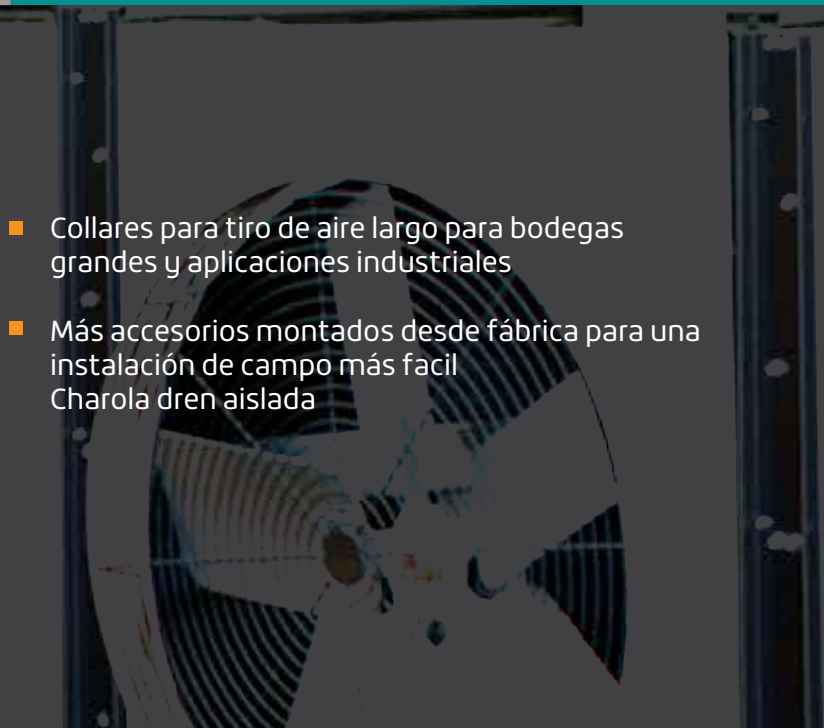

- Collares para tiro de aire largo para bodegas grandes y aplicaciones industriales
- Más accesorios montados desde fábrica para una instalación de campo más fácil  
Charola dren aislada



# FBHA FBHE-FBHL FBHG-FBHF

## EVAPORADORES PERFIL ALTO



Motores

Motores 850 rpm totalmente cerrados aprobados por U.L.\*



Tablero

Eficiente tablero terminales que simplifican sus conexiones a la unidad condensadora



Condensador

Charola del dren abatible del frente facilitando el acceso\*



Guardas

Guardas del ventilador que proporcionan una adecuada difusión del aire\*



Serpentín

Diseño innovador del serpentín Thermo-Flex™ (patente U.S. No. 5,584,340) que elimina la posibilidad de fugas de refrigerante en los tubos que pasan por las cabezeras o secciones de soporte

Evaporadores grandes para uso pesado en aplicaciones de bodegas en refrigeración o congelación. Con un rango de capacidad más amplio y el diseño de serpentín thermo-flex patentado, estos evaporadores grandes proporcionan una operación eficiente y confiable.

Todas sus características y opciones en esta línea de producto están enfocadas a ofrecer al mercado un evaporador para servicio pesado de una calidad superior.

# FBHA | DESHIELO POR AIRE | ESPECIFICACIONES

MODELOS BHA-BHE

Modelo	No. De Ven	Entrada Serpentin	Conexiones (pulgadas)			Peso	
			Succión	Igualador Externo	Dren*	lbs.	Kg
<b>MODELOS DE 6 APP</b>							
520	2	1-1 / 8 DE	1-5 / 8 DE	1 / 4 DE	1 -1 / 4 RTH	270	120
630	2	1-1 / 8 DE	1-5 / 8 DE	1 / 4 DE	1 1 / 4 RTH	300	140
750	3	1-3 / 8 DE	2-1 / 8 DE	1 / 4 DE	1 1 / 4 RTH	390	180
850	3	1-3 / 8 DE	2-1 / 8 DE	1 / 4 DE	1 1 / 4 RTH	430	200
930	4	1-3 / 8 DE	2-1 / 8 DE	1 / 4 DE	1 1 / 4 RTH	515	230
1100	4	1-3 / 8 DE	2-1 / 8 DE	1 / 4 DE	1 -1 / 4 RTH	565	260
1170	3	1-3 / 8 DE	2-1 / 8 DE	1 / 4 DE	1 -1 / 4 RTH	738	330
1400	3	1-5 / 8 DE	2-1 / 8 DE	1 / 4 DE	1 1 / 4 RTH	800	360
1610	3	1-3 / 8 DE ( 2 Conex.)	2-1 / 8 DE ( 2 Conex.)	1 / 4 DE ( 2 Conex.)	1 1 / 4 RTH	850	390
1900	3	1-3 / 8 DE	2-5 / 8 DE	1 / 4 DE	1 -1 / 4 RTH	1160	530
2200	4	1-3 / 8 DE	2-5 / 8 DE	1 / 4 DE	1 -1 / 4 RTH	1500	680
2440	4	1-5 / 8 DE	2-5 / 8 DE	1 / 4 DE	1 -1 / 4 RTH	1600	730
<b>MODELOS DE 8 APP</b>							
2160	3	1-3 / 8 DE	2-5 / 8 DE	1 / 4 DE	1 -1 / 4 RTH	1160	730
2500	4	1-3 / 8 DE	2-5 / 8 DE	1 / 4 DE	1 -1 / 4 RTH	1500	680
2780	4	1-3 / 8 DE	2-5 / 8 DE	1 / 4 DE	1 -1 / 4 RTH	1600	730

ESPECIFICACIONES

# FBHE/FBHL | DESHIELO ELÉCTRICO | ESPECIFICACIONES

Modelo	No. De Ven	Entrada Serpentin	Conexiones (pulgadas)			Peso	
			Succión	Igualador Externo	Dren*	lbs.	Kg
<b>MODELOS DE 6 APP</b>							
450	2	1-1 / 8 DE	1-5 / 8 DE	1 / 4 DE	1 -1 / 4 RTH	280	120
550	2	1-1 / 8 DE	1-5 / 8 DE	1 / 4 DE	1 -1 / 4 RTH	310	140
640	3	1-3 / 8 DE	2-1 / 8 DE	1 / 4 DE	1 -1 / 4 RTH	405	180
740	3	1-3 / 8 DE	2-1 / 8 DE	1 / 4 DE	1 -1 / 4 RTH	445	200
810	4	1-5 / 8 DE	2-1 / 8 DE	1 / 4 DE	1 -1 / 4 RTH	535	230
950	4	1-3 / 8 DE	2-1 / 8 DE	1 / 4 DE	1 -1 / 4 RTH	585	260
1020	3	1-3 / 8 DE	2-1 / 8 DE	1 / 4 DE	1 -1 / 4 RTH	753	330
1200	3	1-5 / 8 DE	2-1 / 8 DE	1 / 4 DE	1 -1 / 4 RTH	815	360
1390	3	1-3 / 8 DE ( 2 Conexi.)	2-1 / 8 DE ( 2 Conexi.)	1 / 4 DE ( 2 Conex.)	1 -1 / 4 RTH	865	390
1650	3	1-3 / 8 DE	2-5 / 8 DE	1 / 4 DE	1 -1 / 4 RTH	1175	530
2120	4	1-3 / 8 DE	2-5 / 8 DE	1 / 4 DE	1 -1 / 4 RTH	1620	680
<b>MODELOS DE 4 APP</b>							
400	2	1-1 / 8 DE	1-5 / 8 DE	1 / 4 DE	1 -1 / 4 RTH	227	130
480	2	1-1 / 8 DE	1-5 / 8 DE	1 / 4 DE	1 -1 / 4 RTH	306	140
560	3	1-3 / 8 DE	2-1 / 8 DE	1 / 4 DE	1 -1 / 4 RTH	400	180
650	3	1-3 / 8 DE	2-1 / 8 DE	1 / 4 DE	1 -1 / 4 RTH	440	200
710	4	1-3 / 8 DE	2-1 / 8 DE	1 / 4 DE	1 -1 / 4 RTH	528	240
840	4	1-3 / 8 DE	2-1 / 8 DE	1 / 4 DE	1 -1 / 4 RTH	578	260
890	3	1-3 / 8 DE	2-1 / 8 DE	1 / 4 DE	1 -1 / 4 RTH	744	340
1050	3	1-5 / 8 DE	2-1 / 8 DE	1 / 4 DE	1 -1 / 4 RTH	805	370
1220	3	1-3 / 8 DE ( 2 Conexi.)	2-1 / 8 DE ( 2 Conexi.)	1 / 4 DE ( 2 Conex.)	1 -1 / 4 RTH	854	390
1440	3	1-5 / 8 DE	2-5 / 8 DE	1 / 4 DE	1 -1 / 4 RTH	1160	530
1860	4	1-5 / 8 DE	2-5 / 8 DE	1 / 4 DE	1 -1 / 4 RTH	1600	730

PERFIL ALTO

Conexión roscada hembra.



Modelo	No. De Ven	Entrada Serpentin	Conexiones (pulgadas)			Gas Caliente	Conex en la Charola para g.c.	Peso	
			Succión	Igualador Externo	Dren*			lbs.	Kg
<b>MODELOS DE 6 APP</b>									
450	2	1-3 / 8 DE	1-5 / 8 DE	1 / 4 DE	1 -1 / 4 RTH	7 / 8	1 - 1 / 8	280	130
550	2	1-1 / 8 DE	1-5 / 8 DE	1 / 4 DE	1 -1 / 4 RTH	7 / 8	1 - 1 / 8	810	150
640	3	1-3 / 8 DE	2-1 / 8 DE	1 / 4 DE	1 -1 / 4 RTH	7 / 8	1 - 1 / 8	405	180
740	3	1-3 / 8 DE	2-1 / 8 DE	1 / 4 DE	1 -1 / 4 RTH	1 - 1 / 8	1 - 1 / 8	445	200
810	4	1-3 / 8 DE	2-1 / 8 DE	1 / 4 DE	1 -1 / 4 RTH	7 / 8	1 - 1 / 8	535	240
950	4	1-5 / 8 DE	2-1 / 8 DE	1 / 4 DE	1 -1 / 4 RTH	1 - 1 / 8	1 - 1 / 8	585	270
1020	3	1-5 / 8 DE	2-1 / 8 DE	1 / 4 DE	1 -1 / 4 RTH	1 - 1 / 8	1 - 3 / 8	753	340
1200	3	1-5 / 8 DE	2-1 / 8 DE	1 / 4 DE	1 -1 / 4 RTH	1 - 1 / 8	1 - 3 / 8	815	370
1390	3	1-3 / 8 DE ( 2 Conexi.)	2-1 / 8 DE ( 2 Conexi.)	1 / 4 DE ( 2 Conexi.)	1 -1 / 4 RTH	7 / 8 ( 2 Conex.)	1 - 3 / 8	865	390
1650	3	1-3 / 8 DE ( 2 Conexi.)	2-5 / 8 DE ( 2 Conexi.)	1 / 4 DE ( 2 Conex.)	1 -1 / 4 RTH	7 / 8 ( 2 Conex.)	1 - 5 / 8 +	1175	530
2120	4	1-3 / 8 DE ( 2 Conexi.)	2-5 / 8 DE ( 2 Conexi.)	1 / 4 DE ( 2 Conex.)	1 -1 / 4 RTH	7 / 8 ( 2 Conex.)	1 - 5 / 8+	1620	730
<b>MODELOS DE 4 APP</b>									
400	2	1-3 / 8 DE	1-5 / 8 DE	1 / 4 DE	1 -1 / 4 RTH	7 / 8	1 - 1 / 8	277	130
480	2	1-5 / 8 DE	1-5 / 8 DE	1 / 4 DE	1 -1 / 4 RTH	7 / 8	1 - 1 / 8	306	150
560	3	1-2 / 8 DE	2-1 / 8 DE	1 / 4 DE	1 -1 / 4 RTH	7 / 8	1 - 1 / 8	400	180
650	3	1-5 / 8 DE	2-1 / 8 DE	1 / 4 DE	1 -1 / 4 RTH	1 - 1 / 8	1 - 1 / 8	440	200
710	4	1-3 / 8 DE	2-1 / 8 DE	1 / 4 DE	1 -1 / 4 RTH	7 / 8	1 - 1 / 8	528	240
840	4	1-5 / 8 DE	2-1 / 8 DE	1 / 4 DE	1 -1 / 4 RTH	1 - 1 / 8	1 - 1 / 8	578	260
890	3	1-5 / 8 DE	2-1 / 8 DE	1 / 4 DE	1 -1 / 4 RTH	1 - 1 / 8	1 - 3 / 8	744	340
1050	3	1-5 / 8 DE	2-1 / 8 DE	1 / 4 DE	1 -1 / 4 RTH	1 - 1 / 8	1 - 3 / 8	805	370
1220	3	1-3 / 8 DE ( 2 Conexi.)	2-1 / 8 DE ( 2 Conexi.)	1 / 4 DE ( 2 Conex.)	1 -1 / 4 RTH	7 / 8 ( 2 Conex.)	1 - 3 / 8	854	390
1440	3	1-3 / 8 DE ( 2 Conexi.)	2-5 / 8 DE ( 2 Conexi.)	1 / 4 DE ( 2 Conex.)	1 -1 / 4 RTH	7 / 8 ( 2 Conex.)	1 - 5 / 8 +	1150	530
1860	4	1-3 / 8 DE ( 2 Conexi.)	2-5 / 8 DE ( 2 Conexi.)	1 / 4 DE ( 2 Conex.)	1 -1 / 4 RTH	7 / 8 ( 2 Conex.)	1 - 5 / 8+	1600	730

**FBHA | DESHIELO POR AIRE | CAPACIDADES**

Modelo	CAPACIDAD BTUH /k cal/Hr 10°F(5.5 5°C)DT +25°F(-3 . 9°C)TSS		DATOS DEL VENTILADOR									HP c/u	DATOS DEL MOTOR ESTANDAR	
	BTUH	kcal/Hr	PCM	m³/Hr	No.	Diámetro		Tiro de aire Estándar		Tiro de aire c/collar			Amps. Totales	
						Pulg.	mm.	pies	m	pies	m		230/3/60	460 /3/ 60
<b>MODELOS DE 6 APP</b>														
FBHA520	52000	13098	9400	16000	2	24	610	70	21	85	26	1/2+		
FBHA630	63000	15869	9000	15300	2	24	610	70	21	85	26	1/2+	7.2	3.6
FBHA750	75000	18892	13200	22400	3	24	610	70	21	85	26	1/2+	10.8	5.4
FBHA850	85000	21211	12800	21400	3	24	610	70	21	85	26	1/2+	10.8	5.4
FBHA930	93000	23426	17600	29900	4	24	610	70	21	85	26	1/2+	14.4	7.2
FBHA1100	110000	27708	16800	28600	4	24	610	70	21	85	26	1/2+	14.4	7.2
FBHA1170	117000	29471	21800	37200	3	30	762	100	30	115	35	1	14.4	7.2
FBHA1400	140000	35264	20700	35200	3	30	762	100	30	115	35	1	14.4	7.2
FBHA1610	161000	40554	24300	41300	3	30	762	100	30	115	35	1 1/2+	19.8	9.9
FBHA1900	190000	47859	26550	45100	3	30	762	120	37	140	43	1 1/2+	17.4	8.7
FBHA2200	220000	55416	30400	51700	4	30	762	120	37	140	43	1 1/2+	26.4	13.2
FBHA2440	244000	61461	35400	60200	4	30	762	120	37	140	43	1 1/2+	23.2	11.6
<b>MODELOS DE 8 APP</b>														
FBHA2160	216000	54408	25950	44100	3	30	762	120	37	140	43	1 1/2+	17.4	8.7
FBHA2500	250000	62972	29600	50300	3	30	762	120	37	140	43	1 1/2+	17.4	8.7
FBHA2780	278000	70025	34600	58800	3	30	762	120	37	140	43	1 1/2+	17.4	8.7

**FBHE | DESHIELO ELÉCTRICO | CAPACIDADES**

Modelo	CAPACIDAD BTUH / kcal/Hr 10°F(5.5 5°C)DT -20°F (-29°C) TSS		DATOS DEL VENTILADOR									HP c/u	DATOS DEL MOTOR ESTANDAR Amps Totales		Resistencia deshielo			
	BTUH	kcal/Hr	PCM	m³/Hr	No.	Diámetro		Tiro de aire Estándar		Tiro de aire c/collar			208 - 230/3/60	460 / 3 / 60	Watts	208 - 230/3/ 60	460/3/60	575/ 3/60
						pulg	mm	pies	m	pies	m							
<b>MODELOS DE 6 APP</b>																		
FBHE 450	45000	11335	9400	16000	2	24	610	70	21	85	26	1/2+	7.2	3.6	9900	27.5	13.9	11.1
FBHE 550	55000	13854	9000	15300	2	24	610	70	21	85	26	1/2+	7.2	3.6	9900	27.5	13.9	11.1
FBHE 640	64000	16121	13200	22400	3	24	610	70	21	85	26	1/2+	10.8	5.4	12900	35.8	18.1	14.5
FBHE 740	74000	18640	12600	21400	3	24	610	70	21	85	26	1/2+	10.8	5.4	12900	35.8	18.1	14.5
FBHE 810	81000	20403	17609	29900	4	24	610	70	21	85	26	1/2+	14.4	7.2	17050	47.8	24.3	19.1
FBHE 950	95000	23929	16800	26600	4	24	610	70	21	85	26	1/2+	14.4	7.2	17050	47.8	24.3	19.1
FBHE 1020	102000	25693	21900	37200	3	30	762	100	30	115	35	1	14.4	7.2	21400	64.2	32.1	22.8
FBHE 1200	120000	30227	20700	35200	3	30	762	100	30	115	35	1	14.4	7.2	21400	64.2	32.1	22.8
FBHE 1390	139000	35013	24300	41300	3	30	762	100	30	115	35	1 1/2	19.8	9.9	21400	64.2	32.1	22.8
FBHE 1650	165000	41562	26550	45100	3	30	762	100	37	140	43	1 1/2	17.4	8.7	37100	95.6	47.8	38.2
FBHE 2120	212000	53401	35400	60200	4	30	762	100	37	140	43	1 1/2	23.2	11.6	49600	128.4	70.0	56.0
<b>MODELOS DE 4 APP</b>																		
FBHL 400	40000	10076	9800	16700	2	24	610	70	21	85	26	1/2+	7.2	3.6	9900	27.5	13.9	11.1
FBHL 480	48000	12091	9400	16000	2	24	610	70	21	85	26	1/2+	7.2	3.6	9900	27.5	13.9	11.1
FBHL 560	56000	14106	13800	23500	3	24	610	70	21	85	26	1/2+	10.8	5.4	12900	35.8	18.1	14.5
FBHL 650	65000	16373	13200	22400	3	24	610	70	21	85	26	1/2+	10.8	5.4	12900	35.8	18.1	14.5
FBHL 710	71000	17884	18400	31300	4	24	610	70	21	85	26	1/2+	14.4	7.2	17050	47.8	24.3	19.1
FBHL 840	84000	21159	17600	29900	4	24	610	70	21	85	26	1/2+	14.4	7.2	17050	47.8	24.3	19.1
FBHL 890	89000	22418	22800	38800	3	30	762	100	30	115	35	1	14.4	7.2	21400	64.2	32.1	22.8
FBHL 1050	105000	26448	21600	36700	3	30	762	100	30	115	35	1	14.4	7.2	21400	64.2	32.1	22.8
FBHL 1220	122000	30730	25200	42800	3	30	762	100	30	115	35	1 1/2	19.8	9.9	21400	64.2	32.1	22.8
FBHL 1440	144000	36272	27600	46900	3	30	762	100	37	140	43	1 1/2	17.4	8.7	37100	95.6	47.8	38.2
FBHL 1860	186000	46851	36800	62600	4	30	762	100	37	140	43	1 1/2	23.2	11.6	49600	128.4	70.0	56.0



Modelo	CAPACIDAD BTUH / kcal/Hr 10°F(5.5 5°C)DT -20°F (-29°C) TSS		DATOS DEL VENTILADOR									DATOS DEL MOTOR ESTANDAR Amps Totales		Resistencia deshielo				
	BTUH	kcal/Hr	PCM	m³/Hr	No.	Diámetro		Tiro de aire Estándar		Tiro de aire c/collar		HP c/u	208 - 230/3/60	460 / 3 / 60	Watts	208 -230/3/ 60	460/3/60	575/ 3/60
						pulg	mm	pies	m	pies	m							
<b>MODELOS DE 6 APP</b>																		
FBHG 450	45000	11335	9400	16000	2	24	610	70	21	85	26	1/2+	7.2	3.6	2100	9.2	4.6	3.7
FBHG 550	55000	13854	9000	15300	2	24	610	70	21	85	26	1/2+	7.2	3.6	2100	9.2	4.6	3.7
FBHG 640	64000	16121	13200	22400	3	24	610	70	21	85	26	1/2+	10.8	5.4	2700	11.8	5.9	4.7
FBHG 740	74000	18640	12600	21400	3	24	610	70	21	85	26	1/2+	10.8	5.4	2700	11.8	5.9	4.7
FBHG 810	81000	20403	17609	29900	4	24	610	70	21	85	26	1/2+	14.4	7.2	4000	17.4	8.7	6.9
FBHG 950	95000	23929	16800	26600	4	24	610	70	21	85	26	1/2+	14.4	7.2	4000	17.4	8.7	6.9
FBHG 1020	102000	25693	21900	37200	3	30	762	100	30	115	35	1	14.4	7.2	4000	17.4	8.7	6.9
FBHG 1200	120000	30227	20700	35200	3	30	762	100	30	115	35	1	14.4	7.2	4000	17.4	8.7	6.9
FBHG 1390	139000	35013	24300	41300	3	30	762	100	30	115	35	1 1/2	17.4	8.7	4000	17.4	8.7	6.9
FBHG 1650	165000	41562	26550	45100	3	30	762	100	37	140	43	1 1/2	17.4	8.7	4200	18.2	9.1	7.3
FBHG 2120	212000	53401	35400	60200	4	30	762	100	37	140	43	1 1/2	23.2	11.6	6200	17.7++	13.4	10.8
<b>MODELOS DE 4 APP</b>																		
FBHF 400	40000	10076	9800	16700	2	24	610	70	21	85	26	1/2+	7.2	3.6	2100	9.2	4.6	3.7
FBHF 480	48000	12091	9400	16000	2	24	610	70	21	85	26	1/2+	7.2	3.6	2100	9.2	4.6	3.7
FBHF 560	56000	14106	13800	23500	3	24	610	70	21	85	26	1/2+	10.8	5.4	2700	11.8	5.9	4.7
FBHF 650	65000	16373	13200	22400	3	24	610	70	21	85	26	1/2+	10.8	5.4	2700	11.8	5.9	4.7
FBHF 710	71000	17884	18400	31300	4	24	610	70	21	85	26	1/2+	14.4	7.2	4000	17.4	8.7	6.9
FBHF 840	84000	21159	17600	29900	4	24	610	70	21	85	26	1/2+	14.4	7.2	4000	17.4	8.7	6.9
FBHF 890	89000	22418	22800	38800	3	30	762	100	30	115	35	1	14.4	7.2	4000	17.4	8.7	6.9
FBHF 1050	105000	26448	21600	36700	3	30	762	100	30	115	35	1	14.4	7.2	4000	17.4	8.7	6.9
FBHF 1220	122000	30730	25200	42800	3	30	762	100	30	115	35	1 1/2	19.8	9.9	4000	17.4	8.7	6.9
FBHF 1440	144000	36272	27600	46900	3	30	762	100	37	140	43	1 1/2	17.4	8.7	4200	18.2	9.1	7.3
FBHF 1860	186000	46851	36800	62600	4	30	762	100	37	140	43	1 1/2	23.2	11.6	6200	17.7++	13.4	10.8

+ Los motores a 208-230/3/60 y 460/3/60 son de 3/4 HP

++ Este modelo es de resistencia trifásica en la Charola Dren.

\* Se encuentra disponible la charola dren con gas caliente.

**FACTORES DE CORRECCIÓN DE CAPACIDAD PARA EVAPORADORES CON DESHIELO ELÉCTRICO Y POR GAS CALIENTE**

Temperatura Saturada de succión °C	(+20 / -6.7)	(-10 / -23.3)	(-20 / -28.9)	(-30 / -34.4)	(-40 / -40)
Multiplicar la capacidad por	1.15	1.04	1.00	0.90	0.80

# FBHE/FBHL ALTO VOLUMEN | DESHIELO ELÉCTRICO | CAPACIDADES

MODELO FBHA-FBHE/FBHL

CAPACIDADES ALTO VOLUMEN

PERFIL ALTO

Modelo	CAPACIDAD BTUH / kcal/Hr 10°F(5.5 5°C)DT -20°F (-29°C) TSS		DATOS DEL VENTILADOR									HP c/u	DATOS DEL MOTOR ESTANDAR Amps Totales		Resistencia deshielo			
	BTUH	kcal/Hr	PCM	m³/Hr	No.	Diámetro		Tiro de aire Estándar		Tiro de aire c/collar			208 - 230/3/60	460 / 3 / 60	Watts	208 - 230/3/60	460/3/60	575/ 3/60
						pulg	mm	pies	m	pies	m							
<b>MODELOS DE 6 APP</b>																		
FBHE 450*V	49500	12469	13600	23100	2	24	610	85	26	100	30	2	15.6	7.8	9900	27.5	13.9	11.1
FBHE 550*V	60500	15239	12200	20700	2	24	610	85	26	100	30	2	15.6	7.8	9900	27.5	13.9	11.1
FBHE 640*V	70400	17733	17700	30100	3	24	610	85	26	100	30	2	23.4	11.7	12900	35.8	18.1	14.5
FBHE 740*V	81400	20504	17000	28900	3	24	610	85	26	100	30	2	23.4	11.7	12900	35.8	18.1	14.5
FBHE 810*V	89100	22443	23600	40100	4	24	610	85	26	100	30	2	31.2	15.6	17050	47.8	24.3	19.1
FBHE 950*V	104000	26196	22600	38400	4	24	610	85	26	100	30	2	31.2	15.6	17050	47.8	24.3	19.1
FBHE 1020*V	107100	26977	25200	42800	3	30	762	110	34	130	40	3	27.6	13.8	21400	64.2	32.1	22.8
FBHE 1200*V	126000	31738	23800	40500	3	30	762	110	34	130	40	3	27.6	13.8	21400	64.2	32.1	22.8
FBHE 1390*V	146000	36776	32800	55800	3	30	762	110	34	130	40	3	27.6	13.8	21400	64.2	32.1	22.8
FBHE 1650*V	174000	43825	29700	50500	3	30	762	130	40	150	46	3	27.6	13.8	37100	95.6	47.8	38.2
FBHE 2120*V	223000	56171	39600	67300	4	30	762	130	40	150	46	3	36.8	18.4	49600	128.4	70.0	56.0
<b>MODELOS DE 4 APP</b>																		
FBHL 400*V	42000	10579	11800	47859	2	24	610	85	26	100	30	2	15.6	7.8	9900	27.5	13.9	11.1
FBHL 480*V	50400	12695	11300	18200	2	24	610	85	26	100	30	2	15.6	7.8	9900	27.5	13.9	11.1
FBHL 560*V	58800	14811	16500	28100	3	24	610	85	26	100	30	2	23.4	11.7	12900	35.8	18.1	14.5
FBHL 650*V	68300	17204	15900	27000	3	24	610	85	26	100	30	2	23.4	11.7	12900	35.8	18.1	14.5
FBHL 710*V	74600	18791	22000	37400	4	24	610	85	26	100	30	2	31.2	15.6	17050	47.8	24.3	19.1
FBHL 840*V	88200	22217	21000	36000	4	24	610	85	26	100	30	2	31.2	15.6	17050	47.8	24.3	19.1
FBHL 890*V	91200	22972	24500	41800	3	30	762	110	34	130	40	3	27.6	13.8	21400	64.2	32.1	22.8
FBHL 1050*V	107600	27103	23300	39600	3	30	762	110	34	130	40	3	27.6	13.8	21400	64.2	32.1	22.8
FBHL 1220*V	125000	31486	27200	46200	3	30	762	110	34	130	40	3	27.6	13.8	21400	64.2	32.1	22.8
FBHL 1440*V	147000	37028	30600	52000	3	30	762	130	40	150	46	3	27.6	13.8	37100	95.6	47.8	38.2
FBHL 1860*V	190000	47859	40800	69400	4	30	762	130	40	150	46	3	36.8	18.4	49600	128.4	70.0	56.0

Los modelos de alto volumen de aire pueden manejar presiones estáticas externas por arriba de 1/2".  
 Los modelos de alto volumen de aire están diseñados para operar por debajo de +15°F (-9.4°C) de TSS.  
 El valor del flujo de aire está determinado para una presión estática externa de 0.0

FACTORES DE CORRECCIÓN DE CAPACIDAD PARA EVAPORADORES CON DESHIELO ELÉCTRICO Y POR GAS CALIENTE					
Temperatura Saturada de succión °C	(+20 / -6.7)	(-10 / -23.3)	(-20 / -28.9)	(-30 / -34.4)	(-40 / -40)
Multiplicar la capacidad por	1.15	1.04	1.00	0.90	0.80



# FBHG/FBHF ALTO VOLUMEN | DESHIELO POR GAS CALIENTE | CAPACIDADES

Modelo	CAPACIDAD BTUH / kcal/Hr 10°F(5.5 5°C)DT -20°F (-29°C) TSS		DATOS DEL VENTILADOR								HP c/u	DATOS DEL MO- TOR ESTANDAR Amps Totales		Resistencia deshielo				
	BTUH	kcal/Hr	PCM	m³/Hr	No.	Diámetro		Tiro de aire Estándar		Tiro de aire c/collar		208 - 230/3/60	460 / 3 / 60	Watts	208 -230/3/ 60	460/3/60	575/ 3/60	
						pulg	mm	pies	m	pies								m
<b>MODELOS DE 6 APP</b>																		
FBHG 450*V	49500	12469	13600	23100	2	24	610	85	26	100	30	2	15.6	7.8	2100	9.2	4.6	3.7
FBHG 550*V	60500	15239	12200	20700	2	24	610	85	26	100	30	2	15.6	7.8	2100	9.2	4.6	3.7
FBHG 640*V	70400	17733	17700	30100	3	24	610	85	26	100	30	2	23.4	11.7	2700	11.8	5.9	4.7
FBHG 740*V	81400	20504	17000	28900	3	24	610	85	26	100	30	2	23.4	11.7	2700	11.8	5.9	4.7
FBHG 810*V	89100	22443	23600	40100	4	24	610	85	26	100	30	2	31.2	15.6	4000	17.4	8.7	6.9
FBHG 950*V	104000	26196	22600	38400	4	24	610	85	26	100	30	2	31.2	15.6	4000	17.4	8.7	6.9
FBHG 1020*V	107100	26977	25200	42800	3	30	762	110	34	130	40	3	27.6	13.8	4000	17.4	8.7	6.9
FBHG 1200*V	126000	31738	23800	40500	3	30	762	110	34	130	40	3	27.6	13.8	4000	17.4	8.7	6.9
FBHG 1390*V	146000	36776	32800	55800	3	30	762	110	34	130	40	3	27.6	13.8	4000	17.4	8.7	6.9
FBHG 1650*V	174000	43825	29700	50500	3	30	762	130	40	150	46	3	27.6	13.8	4200	18.2	9.1	7.3
FBHG 2120*V	223000	56171	39600	67300	4	30	762	130	40	150	46	3	36.8	18.4	6200	17.7+	13.4	10.8
<b>MODELOS DE 4 APP</b>																		
FBHF 400*V	42000	10579	11800	47859	2	24	610	85	26	100	30	2	15.6	7.8	2100	9.2	4.6	3.7
FBHF 480*V	50400	12695	11300	18200	2	24	610	85	26	100	30	2	15.6	7.8	2100	9.2	4.6	3.7
FBHF 560*V	58800	14811	16500	28100	3	24	610	85	26	100	30	2	23.4	11.7	2700	11.8	5.9	4.7
FBHF 650*V	68300	17204	15900	27000	3	24	610	85	26	100	30	2	23.4	11.7	2700	11.8	5.9	4.7
FBHF 710*V	74600	18791	22000	37400	4	24	610	85	26	100	30	2	31.2	15.6	4000	17.4	8.7	6.9
FBHF 840*V	88200	22217	21000	36000	4	24	610	85	26	100	30	2	31.2	15.6	4000	17.4	8.7	6.9
FBHF 890*V	91200	22972	24500	41800	3	30	762	110	34	130	40	3	27.6	13.8	4000	17.4	8.7	6.9
FBHF 1050*V	107600	27103	23300	39600	3	30	762	110	34	130	40	3	27.6	13.8	4000	17.4	8.7	6.9
FBHF 1220*V	125000	31486	27200	46200	3	30	762	110	34	130	40	3	27.6	13.8	4000	17.4	8.7	6.9
FBHF 1440*V	147000	37028	30600	52000	3	30	762	130	40	150	46	3	27.6	13.8	4200	18.2	9.1	7.3
FBHF 1860*V	190000	47859	40800	69400	4	30	762	130	40	150	46	3	36.8	18.4	6200	17.7+	13.4	10.8

Los modelos de alto volumen de aire pueden manejar presiones estáticas externas por arriba de 1/2".  
 Los modelos de alto volumen de aire están diseñados para operar por debajo de +15°F (-9.4°C) de TSS.  
 El valor del flujo de aire está determinado para una presión estática externa de 0.0

FACTORES DE CORRECCIÓN DE CAPACIDAD PARA EVAPORADORES CON DESHIELO ELÉCTRICO Y POR GAS CALIENTE					
Temperatura Saturada de succión °C	(+20 / -6.7)	(-10 / -23.3)	(-20 / -28.9)	(-30 / -34.4)	(-40 / -40)
Multiplicar la capacidad por	1.15	1.04	1.00	0.90	0.80

# DIMENSIONES

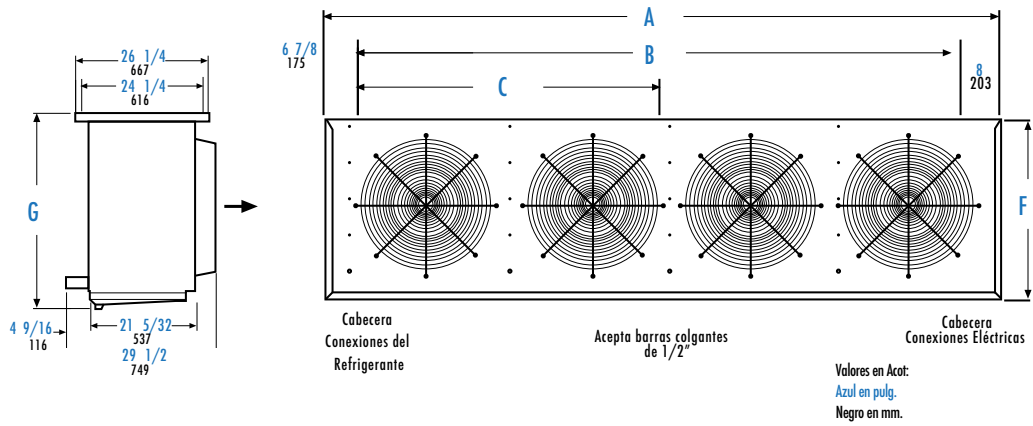

Fig. 1

Deshielo por aire	Eléctrico y gas Caliente		Dimensiones ( pulg. / mm. )									
	6 APP	4 APP	A		B		C		F		G	
			in.	mm	in.	mm	in.	mm	in.	mm	in.	mm
520	450	400	83 3 / 32	2111	68 1 / 8	1730	-	-	37 3 / 16	945	40 11 / 32	1025
630	550	480	83 3 / 32	2111	68 1 / 8	1730	-	-	37 3 / 16	945	40 11 / 32	1025
750	640	560	105 5 / 32	2671	90 3 / 16	2291	45 3 / 32	1145	37 3 / 16	945	40 11 / 32	1025
850	740	650	105 5 / 32	2671	90 3 / 16	2291	45 3 / 32	1145	37 3 / 16	945	40 11 / 32	1025
930	810	710	135 7 / 32	3435	120 1 / 4	3054	60 1 / 8	1527	37 3 / 16	945	40 11 / 32	1025
1100	950	840	135 7 / 32	3435	120 1 / 4	3054	60 1 / 8	1527	37 3 / 16	945	40 11 / 32	1025

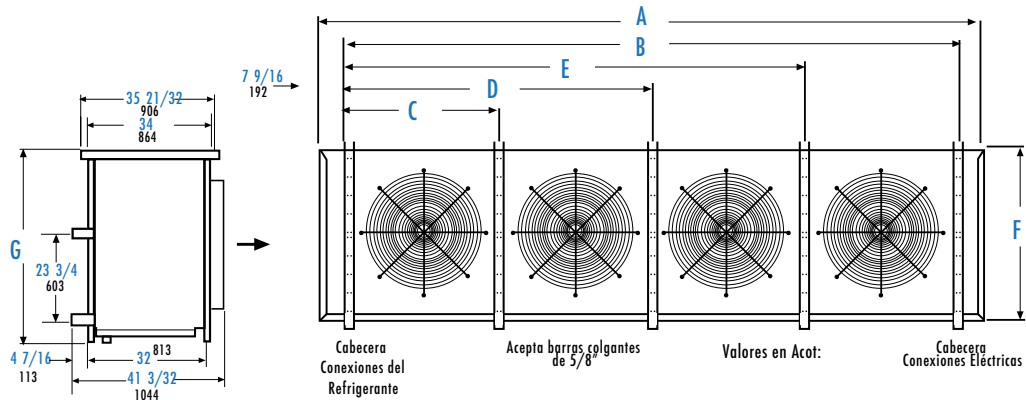

Fig. 2

Deshielo por aire	Eléctrico y gas Caliente			Dimensiones ( pulg. / mm. )													
	6 FPI	6 FPI	4 FPI	A		B		C		D		E		F		G	
				in.	mm	in.	mm	in.	mm	in.	mm	in.	mm	in.	mm		
				135-13/32	3,439	120-9/32	3,055	40-3/32	1,018	80-3/16	2,037	-	-	44-1/2	1,130	50-5/16	1,278
1400	-	1200	1050	135-13/32	3,439	120-9/32	3,055	40-3/32	1,018	80-3/16	2,037	-	-	44-1/2	1,130	50-5/16	1,278
1610	-	1390	1220	135-13/32	3,439	120-9/32	3,055	40-3/32	1,018	80-3/16	2,037	-	-	50-7/32	1,276	55-13/16	1,418
1900	2160	1650	1440	142-1/2	3,620	127-25/32	3,246	42-19/32	1,082	85-3/16	2,164	-	-	50-7/32	1,276	55-13/16	1,418
2200	2500	-	-	185-1/2	4,712	170-3/8	4,328	42-19/32	1,082	85-3/16	2,164	127-25/32	3,246	44-1/2	1,130	50-5/16	1,278
2440	2780	2120	1860	185-1/2	4,712	170-3/8	4,328	42-19/32	1,082	85-3/16	2,164	127-25/32	3,246	50-7/32	1,276	56-1/4	1,429

## TIRO DE AIRE DESHIELO ELÉCTRICO Y GAS CALIENTE

Eléctrico y gas caliente		Motor estándar RPM	HP	Tiro de aire	Tiro de aire con collar	Opcional Alto CFM Motor RPM	Opcional HP	Tiro de aire	Tiro de aire con collar
6 FPI	4 FPI								
450-950	400-840	850	1/2*	70	85	1,750	2	80	0
1020-1390	890-1220	850	1 & 1-1/2	100	120	1.750	3	115	145
1650-2120	1440-1860	1,140	1-1/2	120	145	1,750	3	130	150



# SELECCIÓN DE ESPREAS

Modelo	Ventiladores	Tubo distribuidor		No. de circuitos	R-404A, R-507A Esprea	R-407A, R-407F, R-407C Esprea	R-448A, R-449A Esprea	R-22 Esprea*
		D.E.	Longitud (pulg.)					
Deshielo por aire	FBHA520	2	3/16 25.5	14	E-4	E-4	E-5	E-2-1/2
	FBHA630	2	3/16 25.5	14	E-4	E-4	E-6	E-3
	FBHA750	3	3/16 25.5	21	C-5	C-5	C-8	C-4
	FBHA850	3	3/16 25.5	28	C-6	C-6	C-8	C-4
	FBHA930	4	3/16 25.5	21	C-6	C-6	C-10	C-4
	FBHA1100	4	3/16 25.5	28	C-8	C-8	C-12	C-5
	FBHA1170	3	3/16 28	25	C-8	C-8	C-12	C-5
	FBHA1400	3	3/16 28	34	A-12	A-12	A-15	A-6
	FBHA1610	3	3/16 21.5	19 X 2	2 X C-6	2 X C-6	2 X C-8	2 X C-4
	FBHA1900	3	1/4 32	24	C-15	C-15	C-20	C-12
	FBHA2160	3	1/4 32	19	C-17	C-17	C-25	C-12
	FBHA2200	4	1/4 32	21	C-17	C-17	C-25	C-15
	FBHA2440	4	1/4 32	32	A-20	A-20	A-30	C-15
	FBHA2500	4	1/4 32	21	C-20	C-20	C-25	C-15
	FBHA2780	4	1/4 32	24	C-25	C-25	C-30	C-15
Deshielo eléctrico	FBHE450	2	3/16 25.5	14	E-5	E-5	E-6	E-3
	FBHE550	2	3/16 25.5	14	E-8	E-5	E-8	E-4
	FBHE640	3	3/16 25.5	21	C-8	C-8	C-10	C-5
	FBHE740	3	3/16 25.5	28	C-10	C-10	C-12	C-6
	FBHE810	4	3/16 25.5	21	C-10	C-10	C-12	C-8
	FBHE950	4	3/16 25.5	28	C-15	C-10	C-15	C-8
	FBHE1020	3	3/16 28	25	C-12	C-12	C-15	C-8
	FBHE1200	3	3/16 28	34	A-15	A-15	A-20	A-10
	FBHE1390	3	3/16 21.5	19 X 2	2 X C-8	2 X C-8	2 X C-10	2 X C-5
	FBHE1650	3	1/4 32	24	C-30	C-20	C-30	C-15
	FBHE2120	4	1/4 32	32	A-30	A-30	A-35	A-20
	FBHL400	2	3/16 25.5	14	E-5	E-5	E-6	E-3
	FBHL480	2	3/16 25.5	14	E-8	E-5	E-8	E-4
	FBHL560	3	3/16 25.5	21	C-8	C-8	C-10	C-5
	FBHL650	3	3/16 25.5	28	C-10	C-10	C-12	C-6
	FBHL710	4	3/16 25.5	21	C-10	C-10	C-12	C-8
	FBHL840	4	3/16 25.5	28	C-15	C-10	C-15	C-8
	FBHL890	3	3/16 28	25	C-12	C-12	C-15	C-8
	FBHL1050	3	3/16 28	34	A-15	A-15	A-20	A-10
	FBHL1220	3	3/16 21.5	19 X 2	2 X C-8	2 X C-8	2 X C-10	2 X C-5
FBHL1440	3	1/4 32	24	C-30	C-20	C-30	C-15	
FBHL1860	4	1/4 32	32	A-30	A-30	A-35	A-20	
Deshielo por gas caliente	FBHG450	2	3/16 25.5	14	E-5	E-5	E-6	E-3
	FBHG550	2	3/16 25.5	14	E-5	E-5	E-8	E-4
	FBHG640	3	3/16 25.5	21	C-8	C-8	C-10	C-4
	FBHG740	3	3/16 25.5	28	C-10	C-10	C-12	C-5
	FBHG810	4	3/16 25.5	21	C-10	C-10	C-12	C-5
	FBHG950	4	3/16 25.5	28	C-12	C-12	C-15	C-6
	FBHG1020	3	3/16 28	25	C-12	C-12	C-15	C-6
	FBHG1200	3	3/16 28	34	A-15	A-15	A-17	A-8
	FBHG1390	3	3/16 21.5	19 X 2	2 X C-8	2 X C-8	2 X C-10	2 X C-4
	FBHG1650	3	1/4 24	16 X 2	2 X C-20	2 X C-20	2 X C-30	2 X C-12
	FBHG2120	4	1/4 24	16 X 2	2 X A-30	2 X A-30	2 X A-35	2 X A-17
	FBHF400	2	3/16 25.5	14	E-5	E-5	E-6	E-3
	FBHF480	2	3/16 25.5	14	E-5	E-5	E-8	E-4
	FBHF560	3	3/16 25.5	21	C-8	C-8	C-10	C-4
	FBHF650	3	3/16 25.5	28	C-10	C-10	C-12	C-5
	FBHF710	4	3/16 25.5	21	C-10	C-10	C-12	C-5
	FBHF840	4	3/16 25.5	28	C-12	C-12	C-15	C-6
	FBHF890	3	3/16 28	25	C-12	C-12	C-15	C-6
	FBHF1050	3	3/16 28	34	A-15	A-15	A-17	A-8
	FBHF1220	3	3/16 21.5	19 X 2	2 X C-8	2 X C-8	2 X C-10	2 X C-4
FBHF1440	3	1/4 24	16 X 2	2 X C-20	2 X C-20	2 X C-30	2 X C-12	
FBHF1860	4	1/4 24	16 X 2	2 X A-30	2 X A-30	2 X A-35	2 X A-17	

REFACCIONES PARA EVAPORADORES FBHA			
MODELO	TERMINACIÓN	No. de parte anterior	Nuevo
FBHA520-630-750-850-930-1100	CPA-DPA	7072102	2028070050
FBHA1170-1400	CPA-DPA	2538000	2028010041
FBHA520-630-750-850-930-1100	CTA-DTA	25301001	2028010016
FBHA1610	CTA-DTA	25301101	2028020017
FBHA1610-2200-2500	CPA-DPA	25301701	2028020018
FBHA1900-2160-2440-2780	CPA-DPA	25301801	2028020019
FBHA1900-2160-2440-2780	CTA-DTA	25301101	2028020017
FBHA2200-2500	CTA-DTA	25301101	2028020017
FBHA1170-1400	CTA-DTA	25301101	2028020017
VENTILADOR			
FBHA520-630-750-850-930-1100	CTA-DTA	5133C	2014020021
FBHA 520-630-750-850-930-1100	CPA-DPA	5133C	2014020021
FBHA1170-1400	CPA-DPA	22900401	2014010007
FBHA1900-2160-2440-2780	CTA-DTA	22900101	2014010005
FBHA1170-1400	CTA-DTA	22901501	2014010011
FBHA1610	CTA-DTA	22901501	2014010011
FBHA1610-2200-2500	CPA-DPA	22900301	2014010006
FBHA1900-2160-2440-2780	CPA-DPA	22900101	2014010005
FBHA2200-2500	CTA-DTA	22900101	2014010005
GUARDA			
FBHA520-630-750-850-930-1100		23102203	2023010015
FBHA1170-1400-1610-1900-2160-2200-2440-2500-2780		23102303	2023010029

REFACCIONES PARA EVAPORADORES FBHE			
MODELO	TERMINACIÓN	Nuevo	Anterior
<b>MOTOR</b>			
MODELO	TERMINACIÓN		
FBHE1020-1200	CPA-DPA	2538000	2028010041
FBHE450-550-640-740-810-950	CPA-DPA	7072102	2028070050
FBHE450-550-640-740-810-950	CTA-DTA	25301001	2028010016
FBHE1020-1390-1650-2120	CTA-DTA	25301101	2028020017
FBHE1390	DPA	25301701	2028020018
FBHE1650-2120	CPA-DPA	25301801	2028020019
FBHE450-550-640-740-810-950	CVA-DVA	5916F	2028030043
FBHE1020-1200-1390-1650-2120	CVA-DVA	5926J	2028040068
<b>VELTILADOR</b>			
FBHE1650-2120	CPA-DPA	25900101	2014010005
FBHE1390	CPA-DPA	22900301	2014010006
FBHE1020-1200	CPA-DPA	22900401	2014010007
FBHE450-550-640-740-810-950	CVA-DVA	22901201	2014010009
FBHE1020-1200-1390-1650-2120	CVA-DVA	22901401	2014010010
FBHE1020-1200-1390	CTA-DTA	22901501	2014010011
FBHE450-550-640-740-810-950	CPA-DPA-CTA-DTA	5133C	2014020021
<b>RESISTENCIA PARA SERPENTIN</b>			
FBHE450-550	CPA-DPA-CTA-DTA-CVA-DVA	24711201	2026210621
FBHE640-740	CPA-DPA-CTA-DTA-CVA-DVA	24711202	2026210274
FBHE810-950-1020-1200-1390	CPA-DPA-CTA-DTA-CVA-DVA	24711203	2026210619
FBHE2120	CPA-DPA-CTA-DTA-CVA-DVA	24711403	2026211401
FBHE1650	CPA-DPA-CTA-DTA-CVA-DVA	24712301	2026210277
<b>RESISTENCIA PARA CHAROLA</b>			
FBHE810-950-1020-1200-1390	CPA-DPA-CTA-DTA-CVA-DVA	24710305	2026210268
FBHE1650	CPA-DPA-CTA-DTA-CVA-DVA	24710306	2026210269
FBHE450-550	CPA-DPA-CTA-CVA-DVA	24711301	2026210275
FBHE640-740	CPA-DPA-CTA-DTA-CVA-DVA	24711302	2026210276
FBHE2120	CPA-DPA-CTA-DTA-CVA-DVA	24711402	2026211400
<b>GUARDA</b>			
FBHE-450-550-640-740-810-950		23102203	2023010015
FBHE-1020-1200-1390-1650-2120		23102303	2023010029

REFACCIONES PARA EVAPORADORES FBHL			
MODELO	TERMINACIÓN	Nuevo	Anterior
MOTOR			
MODELO			
FBHL890-1050	CPA-DPA	2538000	2028010041
FBHL400-560-650-710-840	CPA-DPA	7072102	2028070050
FBHL400-480-560-650-710-840	CTA-DTA	25301001	2028010016
FBHL890-1050-1220	CTA-DTA	25301101	2028020017
FBHL1220	CPA-DPA	25301701	2028020018
FBHL400-480-560-650-710-840	CVA-DVA	25305701	2028080022
FBHL400-480-560-650-710-840	CVA-DVA	5916F	2028030043
FBHL890-1050-1220	CVA-DVA	5926J	2028040068
ASPA			
FBHL1220	CPA-DPA	22900301	2014010006
FBHL890-1050	CPA-DPA	22900401	2014010007
FBHL400-480-560-650-710-840	CVA-DVA	22901201	2014010009
FBHL890-1050-1220	CVA-DVA	22901401	2014010010
FBHL890-1050-1220	CTA-DTA	22901501	2014010011
FBHL400-480-560-650-710-840	CPA-DPA-CTA-DTA	5133C	2014020021
RESISTENCIA PARA SERPENTIN			
FBHL400-480	CPA-DPA-CTA-DTA-CVA-DVA	24711201	2026210621
FBHL560-650	CPA-DPA-CTA-DTA-CVA-DVA	24711202	2026210274
FBHL710-840-890-1050-1220	CPA-DPA-CTA-DTA-CVA-DVA	24711203	2026210619
RESISTENCIA PARA CHAROLA			
FBHL710-840-890-1050-1220	CPA-DPA-CTA-DTA-CVA-DVA	24710305	2026210268
FBHL400-480	CPA-DPA-CTA-DTA-CVA-DVA	24711301	2026210275
FBHL560-650	CPA-DPA-CTA-DTA-CVA-DVA	24711302	2026210276

REFACCIONES PARA EVAPORADORES FBHG			
MODELO	TERMINACIÓN	Nuevo	Anterior
MOTOR			
MODELO			
FBHG1020-1200	CPA-DPA	2538000	2028010041
FBHG450-550-640-740-810-950	CPA-DPA	7072102	2028070050
FBHG450-550-640-740-810-950	CTA-DTA	25301001	2028010016
FBHG1020-1200-1390-1650-2120	CTA-DTA	25301101	2028020017
FBHG1390	CPA-DPA	25301701	2028020018
FBHG1650-2120	CPA-DPA	25301801	2028020019
FBHG450-550-640-740-810-950	CVA-DVA	5916F	2028030043
FBHG1020-1200-1390-1650-2120	CVA-DVA	5926J	2028040068
<b>ASPA</b>			
FBHG1650-2120	CPA-DPA-CTA	22900101	2014010005
FBHG1390	DPA	22900301	2014010006
FBHG1020-1200	CPA-DPA	22900401	2014010007
FBHG450-550-640-740-810-950	CVA-DVA	22901201	2014010009
FBHG1020-1200-1390-1650-2120	CVA-DVA	22901401	2014010010
FBHG1020-1200-1390	CTA-DTA	22901501	2014010011
FBHG450-550-640-740-810-950	CPA-DPA-CTA	5133C	2014020021
<b>GUARDA</b>			
FBHG450-550-640-740-810-950	CPA-DPA-CTA-DTA-CVA-DVA	23102203	2023010015
FBHG1020-1200-1390-1650-2120	CPA-DPA-CTA-DTA-CVA-DVA	23102303	2023010029
<b>RESISTENCIA CHAROLA</b>			
FBHG-810-950-1020-1200-1390	CPA-DPA-CTA-DTA-CVA-DVA	24710305	2026210268
FBHG1650	CPA-DPA-CTA-DTA-CVA-DVA	24710306	2026210269
FBHG-450-550	CPA-DPA-CTA-DTA-CVA-DVA	24711301	2026210275
FBHG640-740	CPA-DPA-CTA-DTA-CVA-DVA	24711302	2026210276
FBHG2120	CPA-DPA-CTA-DTA-CVA-DVA	24711402	2026211400

REFACCIONES PARA EVAPORADORES FBHG			
MODELO	TERMINACIÓN	Nuevo	Anterior
MOTOR			
MODELO			
FBHF890-1050	CPA-DPA	2538000	2028010041
FBHF400-480-560-650-710-840	CPA-DPA	7072102	2028070050
FBHF400-480-560-650-710-840	CTA-DTA	25301001	2028010016
FBHF890-1050-1220-1440-1860	CTA-DTA	25301101	2028020017
FBHF1220	CPA-DPA	25301701	2028020018
FBHF1440-1860	CPA-DPA	25301801	2028020019
FBHF400-480-560-650-710-840	CVA-DVA	5916F	2028030043
FBHF890-1050-1220-1440-1860	CVA-DVA	5926J	2028040068
<b>ASPA</b>			
FBHF1440-1860	CPA-DPA	22900101	2014010005
FBHF1220	CPA-DPA	22900301	2014010006
FBHF890-1050	CPA-DPA	22900401	2014010007
FBHF400-480-560-650-710-840	CVA-DVA	22901201	2014010009
FBHF890-1050-1220-1440-1860	CVA-DVA	22901401	2014010010
FBHF890-1050-1220-1440-1860	CTA-DTA	22901501	2014010011
FBHF400-480-560-650-710-840	CPA-DPA-CTA-DTA	5133C	2014020021
<b>GUARDA</b>			
FBHF400-480-560-650-710-840	CPA-DPA-CTA-DVA	23102203	2023010015
FBHF-890-1050-1220-1440-1860	CPA-DPA-CTA-DTA	23102303	2023010029
<b>RESISTENCIA CHAROLA</b>			
FBHF650-710	CPA-DPA	24710302	2026210265
FBHF710-840-890-1050-1220	CPA-DPA-CTA-DTA-CVA-DVA	24710305	2026210268
FBHF1440	CPA-DPA-CTA-DTA	24710306	2026210269
FBHF400-480-560	CPA-DPA-CTA-DTA	24711301	2026210275
FBHF560-650	CTA-DTA-CTA-DVA	24711302	2026210276
FBHF1860	CPA-DPA-CTA-DTA	24711402	2026211400



Call Center:  
+52 55 5000 5105  
[www.fb-refrigeracion.com](http://www.fb-refrigeracion.com)

#### Boletín 430.1, Publicado MAYO-2026, BCT-007

FB se reserva el derecho de hacer cambios en sus especificaciones en cualquier momento, sin previo aviso y sin ninguna responsabilidad con los compradores, propietarios del equipo que previamente se les ha vendido. Las fotografías son descriptivas. Revisar características y especificaciones. V. 1.8

#### Oficinas Corporativas

Bosques de Alisos No. 47-A, Piso 5  
Col. Bosques de las Lomas  
México, DF. C.P. 05120  
Tel: +52 55 5000 5100

#### Planta Querétaro

Acceso II, Calle 2 No. 48  
Parque Industrial Benito Juárez  
Querétaro, Qro. C.P. 76120  
Tel: +52 442 296 4500

#### Planta Mérida

Calle 19 No. 418  
Ampliación Ciudad. Industrial  
C.P. 97930,  
Umán, Yucatán,  
Tel: +52 999 946 3483

#### Planta Monterrey

Parque Industrial Finsa Santa Catarina  
Carretera a Garcia Km. 3.0  
Santa Catarina, N.L.  
Tel: +52 55 5000 8505

#### Guadalajara

Av. Chapultepec No.15 Piso 16 A  
Col. Ladrón de Guevara  
Guadalajara, Jal.  
C.P. 44600  
Tel. +52 33 4624 0080

#### Mazatlán, Sinaloa

San Alfonso #5006  
Fracc. Real del Valle  
Mazatlán Sinaloa  
C.P. 8212  
Tel: +52 667 752 0700  
Cel: +52 667 791 5336

#### Tijuana

Camino del Rey Oeste # 5459-2  
Privada Capri # 2  
Residencial Colinas del Rey  
Tijuana BC, C.P. 22170  
Tel: +52 664 900 3830  
Cel: +52 664 674 1677